

# OK-VISE®

## Tooling Blocks

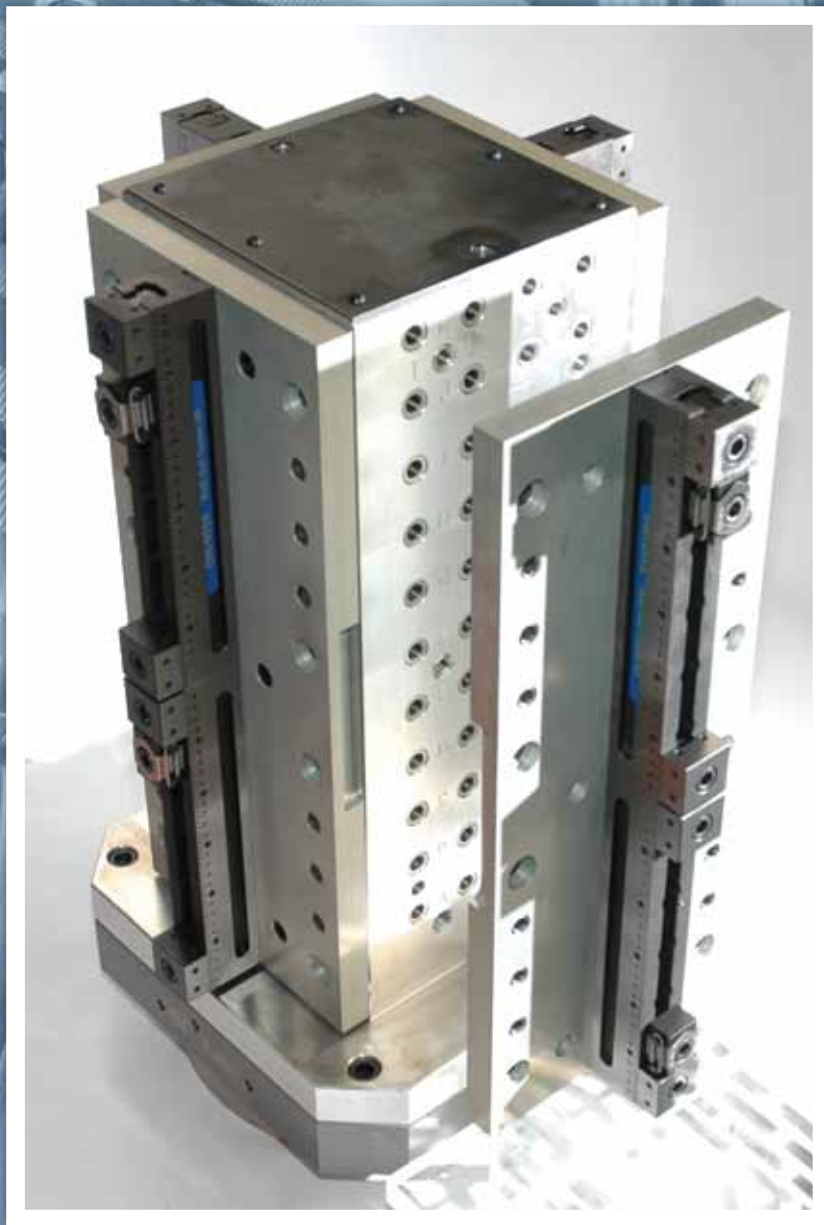

PLATFORMS

In addition to fixturing components manufactured by OK-VISE Oy, we offer work-holding platforms such as tooling blocks.

Most common platform types are T-slot, Grid and Blank platforms. Materials choices are Aluminium or cast iron.

## OK-LOCK TOOLING BLOCK

TALR ( Aluminium ) , TCLR ( Cast Iron )

Platforms using OK-LOCK elements ( such as “OK-LOCK BLOCK” ) allow a radically shorter setup time of fixturing.

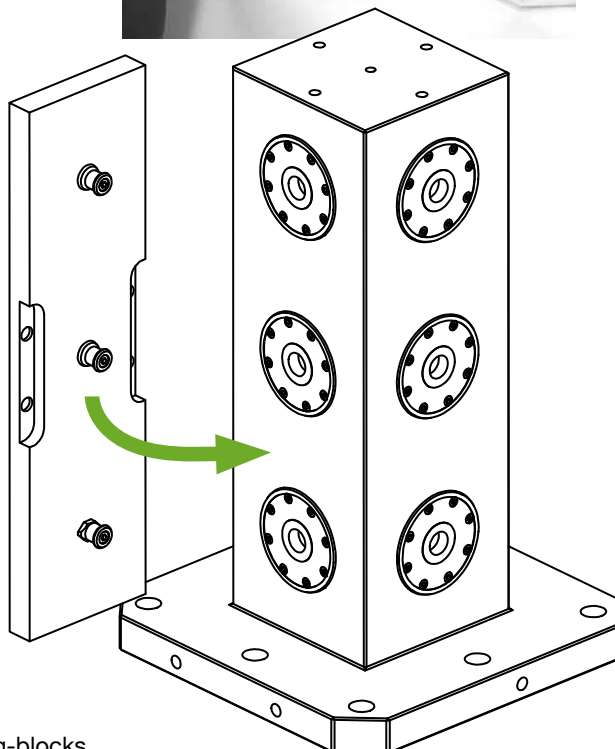
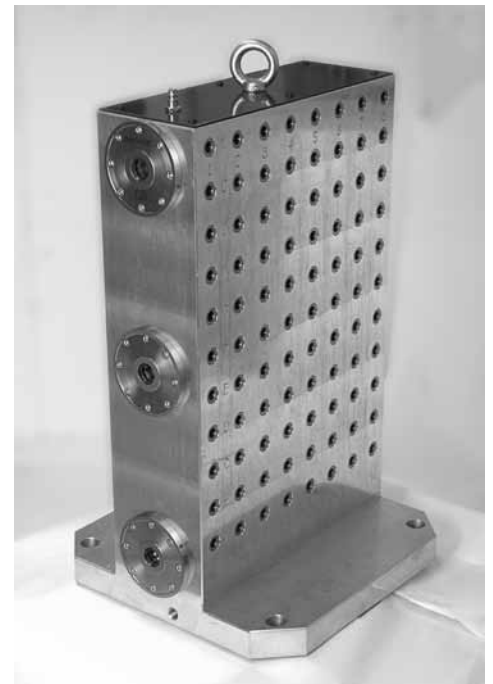

## SQUARE TOOLING COLUMN

TCBS Blank, Cast Iron

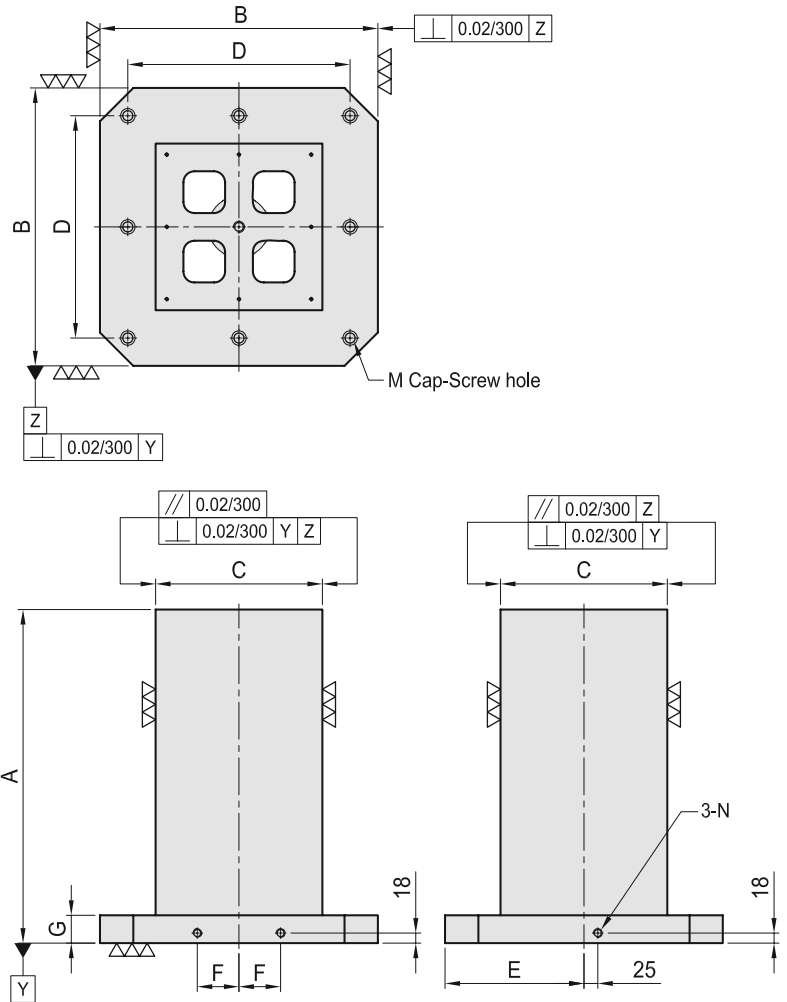

**Material / Finish:**

Material: Cast Iron  
 FC300(JIS) / GG30 (DIN)  
 Head Treated (Normalized)

**Application:**

Horizontal Machining Center.

**Features:**

Ready to accept a hole pattern for your special jig.

Eye bolt & top cover included.

MODEL NO.	A	B	C	D	E	F	G	M	N	Holes	kg
TCBS-305015	500	300	150	250	150	40	50	M12	M12	4	90
TCBS-405025	500	400	250	320	200	55	50	M16	M16	4	160
TCBS-406525	650										210
TCBS-506030	600	500	300	400	250	75	50	M16	M16	8	250
TCBS-507530	750										310
TCBS-637035	700	630	350	500	315	100	50	M16	M16	8	400
TCBS-638535	850										460
TCBS-808050	800	800	500	640	400	135	50	M16	M16	8	680
TCBS-8010050	1000										800
TCBS-10010060	1000	1000	600	800	500	165	55	M20	M16	8	1164
TCBS-10012560	1250										1391

# SQUARE TOOLING COLUMN

TCGS Grid, Cast Iron

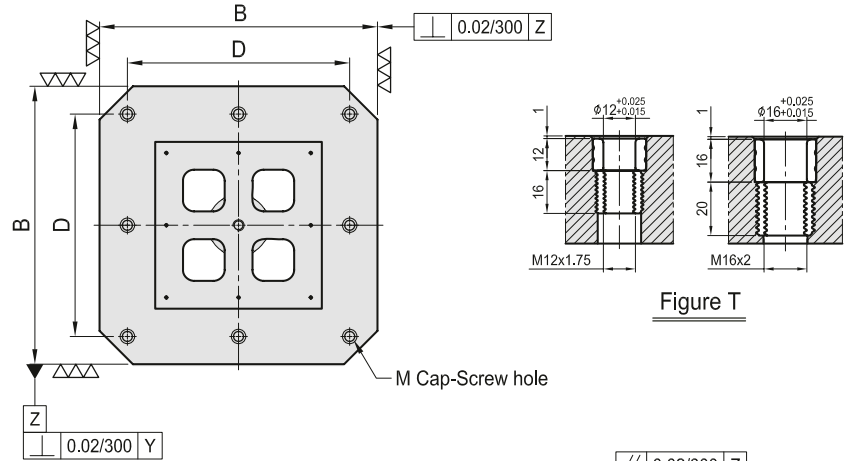
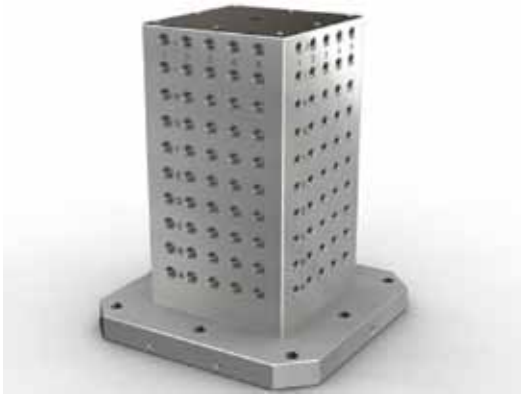
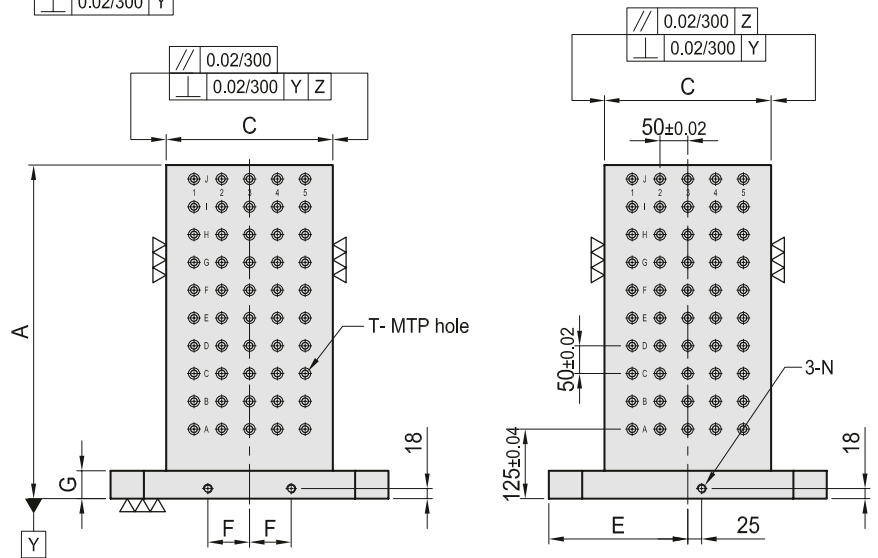

Figure T



**Material / Finish:**

Material: Cast Iron FC300(JIS) / GG30 (DIN)  
Heat treated (Normalized)

**Alignment Busing:**

SUJ2(JIS) / 100Cr6 (DIN), heat treated  
Threaded Insert:  
S45C(JIS) / CK45 (DIN), heat treated  
Grid hole spacing:  $50 \pm 0.02$

**Application:**

Horizontal Machining Center

**Features:**

Alignment bushing & thread insert at every hole location, easily adapts to standardized jig components.

Eye bolt & top cover included

MODEL NO.	A	B	C	D	E	F	G	T	M	N	pcs	Holes	kg
TCGS-305015-12	500	300	150	250	150	40	50	Ø12	M12	M12	64	4	90
TCGS-405025-12	500	300	150	250	150	40	50	Ø12	M12	M12	128	4	155
		400	250	320	200	55	50	Ø12	M12	M16	176	4	200
TGGS-406525-12	650												
TCGS-506030-12	600										200	8	240
TCGS-507530-12	750	500	300	400	250	75	50	Ø12	M12	M16	260	8	300
TCGS-637035-12	700										288	8	360
TCGS-638535-12	850	630	350	500	315	100	50	Ø12	M12	M16	360	8	445
TCGS-808050-12	800										504	8	635
TCGS-8010050-12	1000	800	500	640	400	135	50	Ø12	M12	M16	648	8	780
TCGS-10010060-12	1000										792	8	1164
TCGS-10012560-12	1250	1000	600	800	500	165	55	Ø12	M12	M16	1012	8	1391

MODEL NO.	A	B	C	D	E	F	G	T	M	N	pcs	Holes	kg
TCGS-305015-16	500	300	150	250	150	40	50	Ø16	M12	M12	64	4	90
TCGS-405025-16	500	300	150	250	150	40	50	Ø16	M12	M12	128	4	152
		400	250	320	200	55	50	Ø16	M16	M16	176	4	195
TGGS-406525-16	650												
TCGS-506030-16	600										200	8	235
TCGS-507530-16	750	500	300	400	250	75	50	Ø16	M16	M16	260	8	295
TCGS-637035-16	700										288	8	365
TCGS-638535-16	850	630	350	500	315	100	50	Ø16	M16	M16	360	8	440
TCGS-808050-16	800										504	8	630
TCGS-8010050-16	1000	800	500	640	400	135	50	Ø16	M16	M16	648	8	770
TCGS-10010060-16	1000										792	8	1164
TCGS-10012560-16	1250	1000	600	800	500	165	55	Ø16	M20	M16	1012	8	1391

# SQUARE TOOLING COLUMN

TCTS T-Slot, Cast Iron

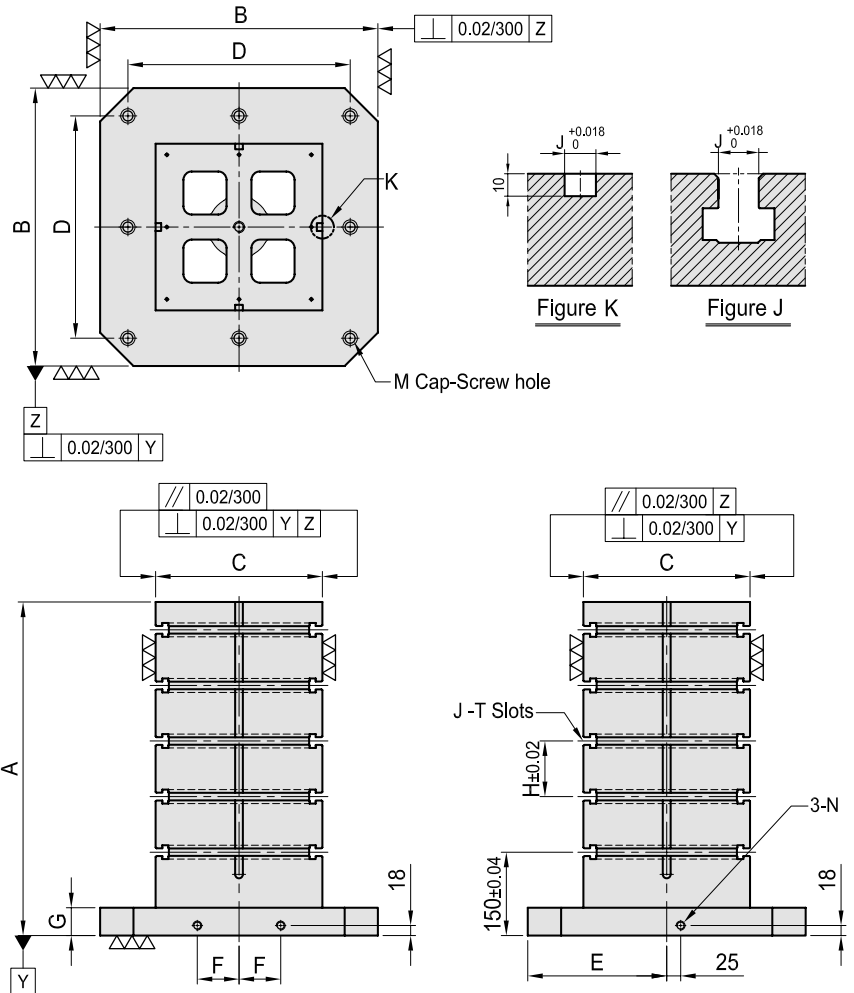
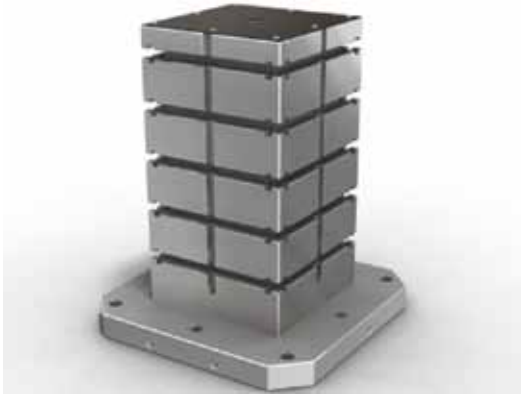

**Material / Finish:**

Material: Cast Iron FC300(JIS) / GG30 (DIN)  
Heat treated (Normalized)

**Application:**

Horizontal Machining Center

**Features:**

T-Slots running horizontally, key-way running vertically, easily adapts to standardized jig components.

Eye bolt & top cover included

MODEL NO.	A	B	C	D	E	F	G	M	N	H	J	Holes	kg
TCTS-405025-14	500												160
		400	250	320	200	55	50	M16	M16	100	14	4	200
TCTS-406524-14	650												270
		500	300	400	250	75	50	M16	M16	100	14	8	300
TCTS-507530-14	750												375
		630	350	500	315	100	50	M16	M16	125	14	8	460
TCTS-637035-14	700												655
		800	500	640	400	135	50	M16	M16	150	14	8	800
TCTS-638535-14	850												1146
		1000	600	800	500	165	55	M20	M16	160	14	8	1358

MODEL NO.	A	B	C	D	E	F	G	M	N	H	J	Holes	kg
TCTS-405025-18	500												155
		400	250	320	200	55	50	M16	M16	100	18	4	190
TCTS-406524-18	650												265
		500	300	400	250	75	50	M16	M16	100	18	8	290
TCTS-507530-18	750												365
		630	350	500	315	100	50	M16	M16	125	18	8	450
TCTS-637035-18	700												638
		800	500	640	400	135	50	M16	M16	150	18	8	790
TCTS-638535-18	850												1146
		1000	600	800	500	165	55	M20	M16	160	18	8	1358

## SQUARE TOOLING COLUMN

TABS Blank, Aluminum

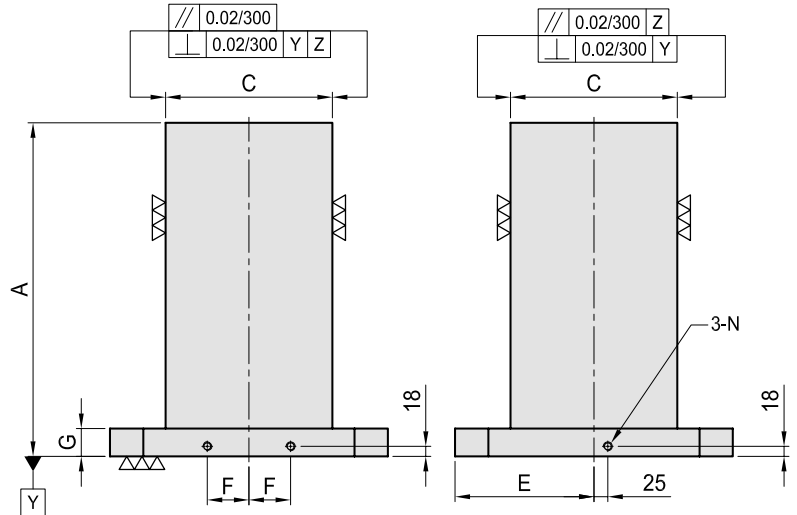
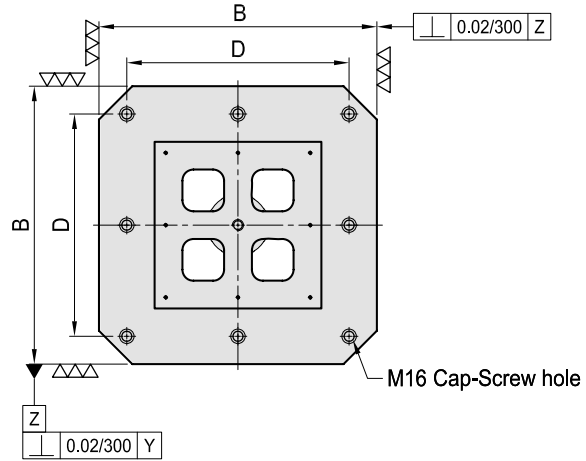

**Material:**

Material: High Strength Aluminum Casting

**Application:**

Horizontal Machining Center

**Features:**

Ready to accept a hole pattern for your special jig.

Eye bolt & top cover included

MODEL NO.	A	B	C	D	E	F	G	Holes	kg
TABS-405025	500	400	250	320	200	55	50	4	56
TABS-406525	650								73
TABS-506030	600	500	300	400	250	75	50	8	91
TABS-507530	750								122
TABS-637035	700	630	350	500	315	100	50	8	129
TABS-638535	850								180
TABS-808050	800	800	500	640	400	135	50	8	215
TABS-8010050	1000								312

# SQUARE TOOLING COLUMN

TAGS Grid, Aluminum

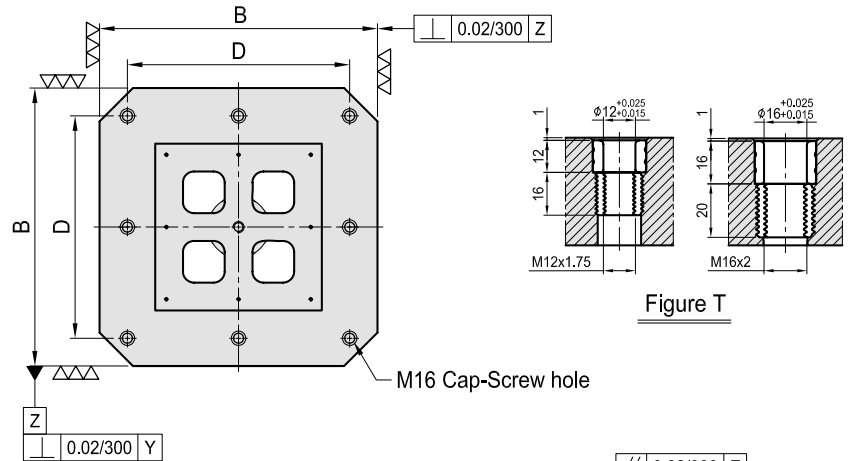
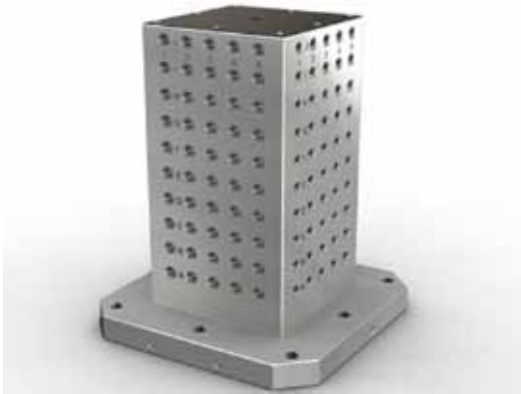

**Material:**

Material: High Strength Aluminum Casting

**Alignment Busing:**

SUJ2(JIS) / 100Cr6 (DIN), heat treated  
 Threaded Insert:  
 S45C(JIS) / CK45 (DIN), heat treated  
 Grid hole spacing:  $50 \pm 0.02$

**Application:**

Horizontal Machining Center

**Features:**

Alignment bushing & thread insert at every hole location, easily adapts to standardized jig components.

Eye bolt & top cover included

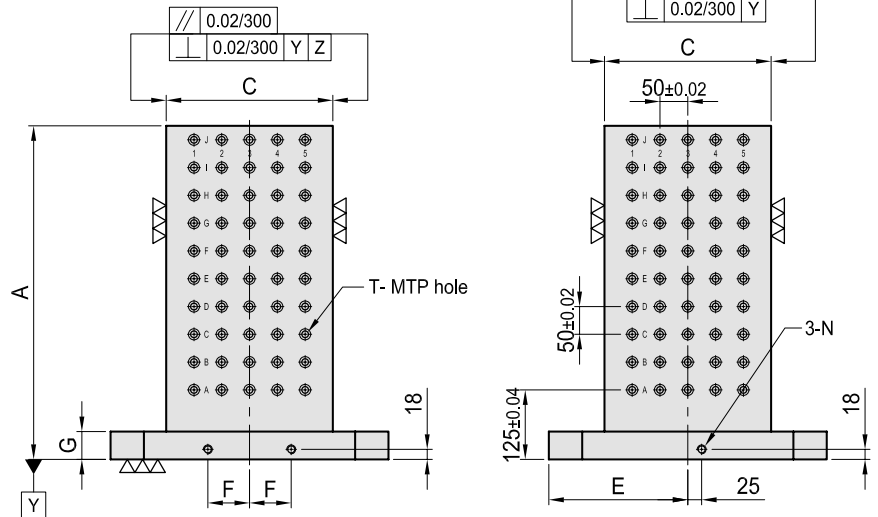

MODEL NO.	A	B	C	D	E	F	G	T	pcs	Holes	kg
TAGS-405025-12	500								128	4	54
TAGS-406525-12	650	400	250	320	200	55	40	$\phi 12$ M12	176	4	73
TAGS-506030-12	600								200	8	88
TAGS-507530-12	750	500	300	400	250	75	40	$\phi 12$ M12	260	8	122
TAGS-637035-12	700								288	8	126
TAGS-638535-12	850	630	350	500	315	100	50	$\phi 12$ M12	360	8	180
TAGS-808050-12	800								504	8	204
TAGS-8010050-12	1000	800	500	640	400	135	50	$\phi 12$ M12	648	8	312

MODEL NO.	A	B	C	D	E	F	G	T	pcs	Holes	kg
TAGS-405025-16	500								128	4	54
TAGS-406525-16	650	400	250	320	200	55	40	$\phi 16$ M16	176	4	73
TAGS-506030-16	600								200	8	88
TAGS-507530-16	750	500	300	400	250	75	40	$\phi 16$ M16	260	8	122
TAGS-637035-16	700								288	8	123
TAGS-638535-16	850	630	350	500	315	100	50	$\phi 16$ M16	360	8	180
TAGS-808050-16	800								504	8	201
TAGS-8010050-16	1000	800	500	640	400	135	50	$\phi 16$ M16	648	8	312

# SQUARE TOOLING COLUMN

TATS T-Slot, Aluminum

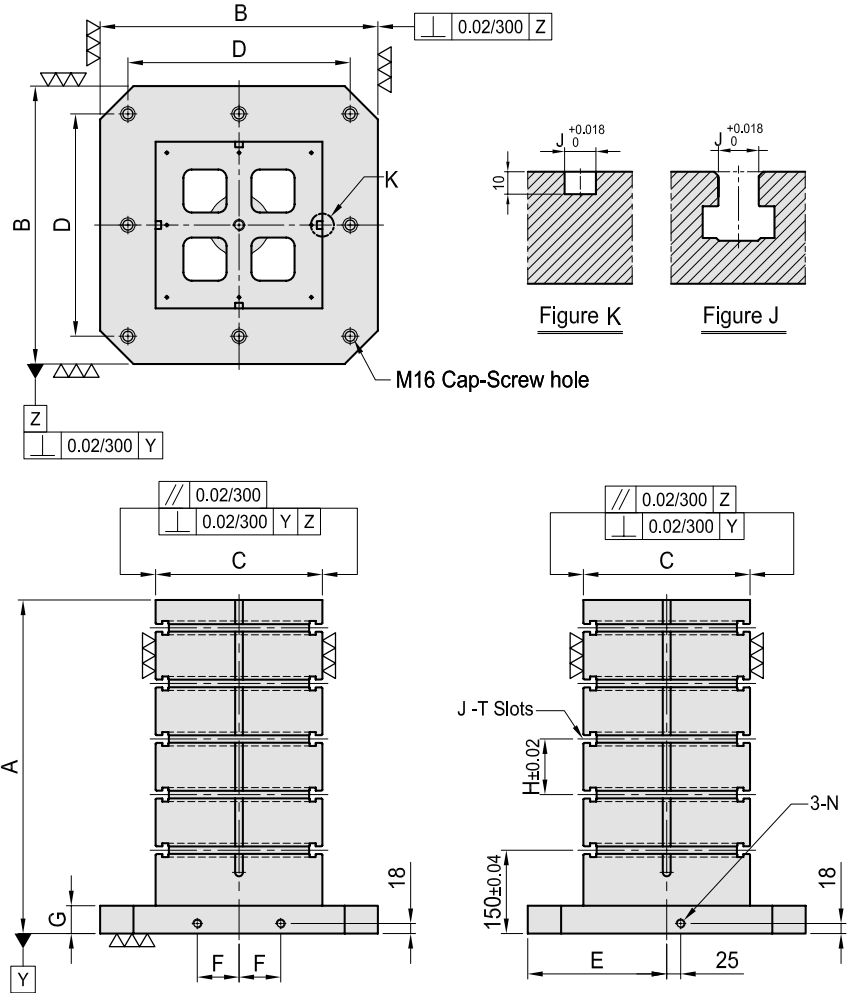
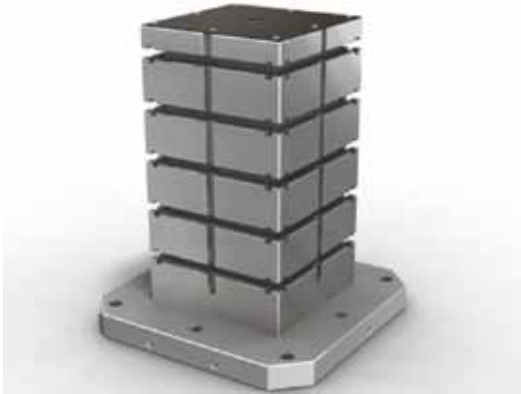

- Material:**  
Material: High Strength Aluminum Casting
- Application:**  
Horizontal Machining Center
- Features:**  
T-Slots running horizontally, key-way running vertically, easily adapts to standardized jig components.
- Eye bolt & top cover included

MODEL NO.	A	B	C	D	E	F	G	H	J	Holes	kg
TATS-405025-14	500										61
TATS-406525-14	650	400	250	320	200	55	40	100	14	4	84
TATS-506030-14	600										86
TATS-507530-14	750	500	300	400	250	75	40	100	14	8	127
TATS-637035-14	700										136
TATS-638535-14	850	630	350	500	315	100	50	125	14	8	183
TATS-808050-14	800										260
TATS-8010050-14	1000	800	500	640	400	135	50	150	14	8	319

MODEL NO.	A	B	C	D	E	F	G	H	J	Holes	kg
TATS-405025-18	500										60
TATS-406525-18	650	400	250	320	200	55	40	100	18	4	84
TATS-506030-18	600										85
TATS-507530-18	750	500	300	400	250	75	40	100	18	8	135
TATS-637035-18	700										135
TATS-638535-18	850	630	350	500	315	100	50	125	18	8	183
TATS-808050-18	800										254
TATS-8010050-18	1000	800	500	640	400	135	50	150	18	8	319



## DOUBLE SIDED TOOLING COLUMN

TCBR Blank, Cast Iron

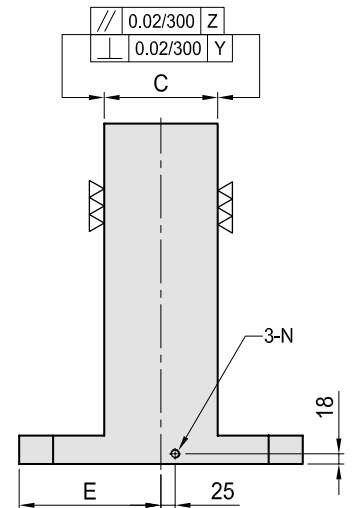
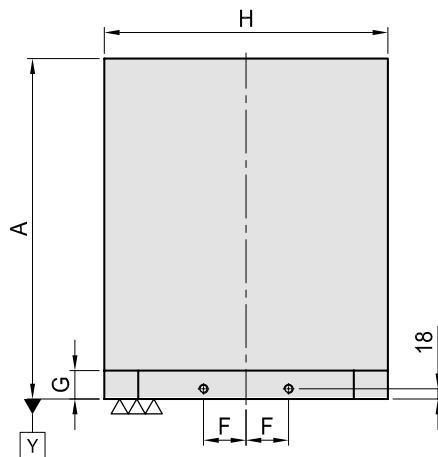
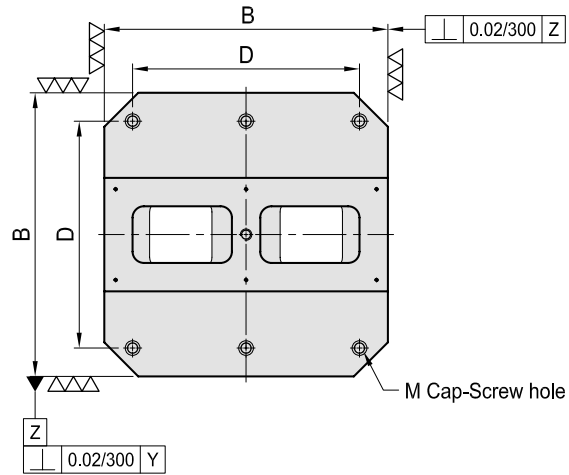

**Material / Finish:**

Material: Cast Iron FC300(JIS) / GG30 (DIN)  
Heat treated (Normalized)

**Application:**

Horizontal Machining Center

**Features:**

Ready to accept a hole pattern for your special jig.

Eye bolt & top cover included

MODEL NO.	A	B	C	D	E	F	G	H	M	N	Holes	kg
TCBR-305008	500	300	80	250	150	40	50	300	M12	M12	4	115
TCBR-405015	500	400	150	320	200	55	50	400	M16	M16	4	170
TCBR-406515	650	400	150	320	200	55	50	400	M16	M16	4	215
TCBR-506020	600	500	200	400	250	75	50	500	M16	M16	6	270
TCBR-507520	750	500	200	400	250	75	50	500	M16	M16	6	350
TCBR-637025	700	630	250	500	315	100	50	630	M16	M16	6	445
TCBR-638525	850	630	250	500	315	100	50	630	M16	M16	6	520
TCBR-808030	800	800	300	640	400	135	50	800	M16	M16	6	675
TCBR-8010039	1000	800	300	640	400	135	50	800	M16	M16	6	815
TCBR-10010035	1000	1000	350	800	500	165	55	1000	M20	M16	6	1162
TCBR-10012535	1250	1000	350	800	500	165	55	1000	M20	M16	6	1377

# DOUBLE SIDED TOOLING COLUMN

TCGR Grid, Cast Iron

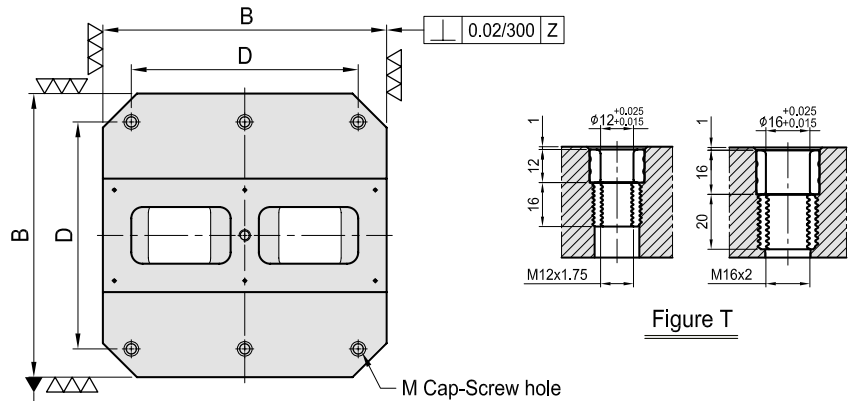

**Material / Finish:**

Material: Cast Iron FC300(JIS) / GG30 (DIN)  
Heat treated (Normalized)

**Alignment Busing:**

SUJ2(JIS) / 100Cr6 (DIN), heat treated  
Threaded Insert:  
S45C(JIS) / CK45 (DIN), heat treated  
Grid hole spacing: 50 ± 0.02

**Application:**

Horizontal Machining Center

**Features:**

Alignment bushing & thread insert at every hole location, easily adapts to standardized jig components.

Eye bolt & top cover included

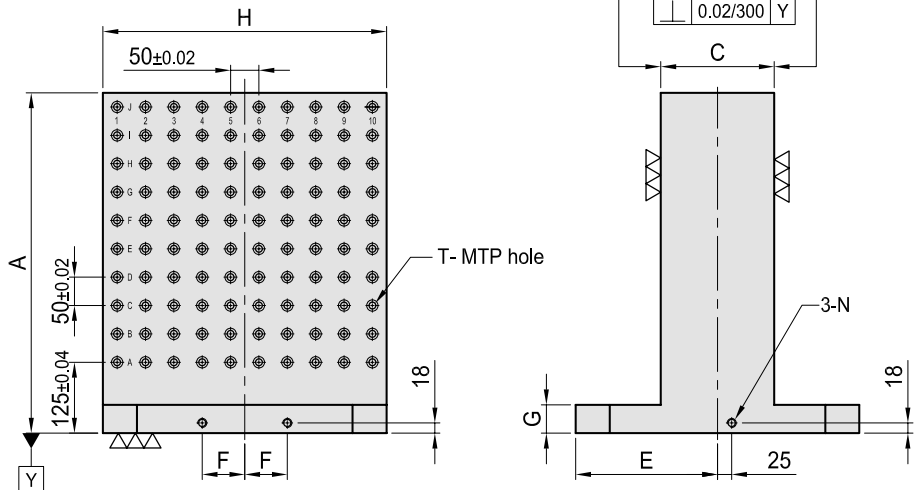

MODEL NO.	A	B	C	D	E	F	G	H	T	M	N	pcs	Holes	kg	MODEL NO.	A	B	C	D	E	F	G	H	T	M	N	pcs	Holes	kg		
TCGR-305008-12	500	300	80	250	150	40	50	300	Ø12	M12	M12	M12	96	4	110	TCGR-305008-16	500	300	80	250	150	40	50	300	Ø16	M16	M12	M12	96	4	105
TCGR-405015-12	500											128	165		TCGR-405015-16	500											128	160			
TCGR-406515-12	650	400	150	320	200	55	50	400	Ø12	M12	M16	M16	176	4	210	TCGR-406515-16	650	400	150	320	200	55	50	400	Ø16	M16	M16	M16	176	4	205
TCGR-506020-12	600											200	265		TCGR-506020-16	600										200	260				
TCGR-507520-12	750	500	200	400	250	75	50	500	Ø12	M12	M16	M16	260	6	335	TCGR-507520-16	750	500	200	400	250	75	50	500	Ø16	M16	M16	M16	260	6	330
TCGR-637025-12	700											288	435		TCGR-637025-16	700									288	430					
TCGR-638525-12	850	630	250	500	315	100	50	630	Ø12	M12	M16	M16	360	6	515	TCGR-638525-16	850	630	250	500	315	100	50	630	Ø16	M16	M16	M16	360	6	505
TCGR-808030-12	800											420	660		TCGR-808030-16	800									420	650					
TCGR-8010030-12	1000	800	300	640	400	135	50	800	Ø12	M12	M16	M16	540	6	800	TCGR-8010030-16	1000	800	300	640	400	135	50	800	Ø16	M16	M16	M16	540	6	790
TCGR-10010035-12	1000											684	1158		TCGR-10010035-16	1000									684	1158					
TCGR-10012535-12	1250	1000	350	800	500	165	55	1000	Ø12	M12	M20	M16	874	6	1375	TCGR-10012535-16	1250	1000	350	800	500	165	55	1000	Ø16	M16	M20	M16	874	6	1375

## DUBLE SIDED TOOLING COLUMN

TCTR T-Slot, Cast Iron

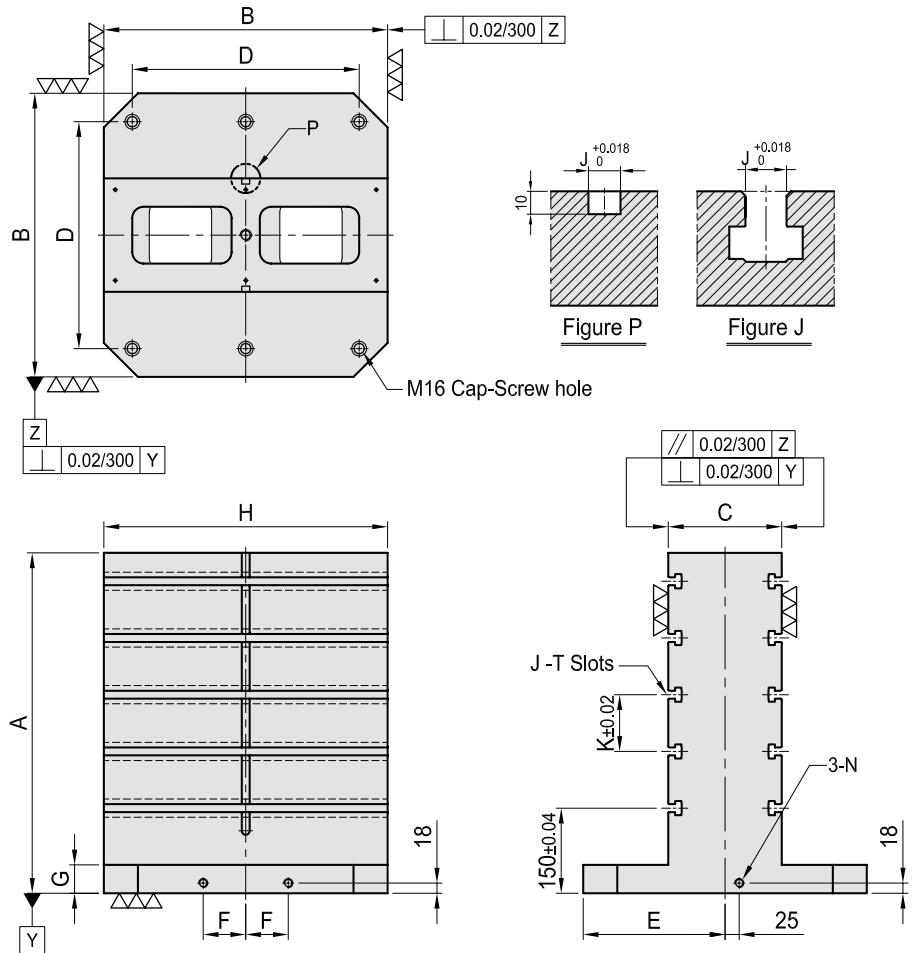

**Material / Finish:**

Material: Cast Iron FC300(JIS) / GG30 (DIN)  
Heat treated (Normalized)

**Application:**

Horizontal Machining Center

**Features:**

T-Slots running horizontally, key-way running vertically, easily adapts to standardized jig components.

Eye bolt & top cover included

MODEL NO.	A	B	C	D	E	F	G	M	N	H	J	K	Holes	kg
TCTR-405015-14	500													170
		400	150	320	200	55	50	M16	M16	400	14	100	4	220
TCTR-406515-14	650													290
		500	200	400	250	75	50	M16	M16	500	14	100	6	335
TCTR-507520-14	750													440
		630	250	500	315	100	50	M16	M16	630	14	125	6	515
TCTR-637025-14	700													670
		800	300	640	400	135	50	M16	M16	800	14	150	6	790
TCTR-638525-14	850													1158
		1000	350	800	500	165	55	M20	M16	1000	14	150	6	1375

MODEL NO.	A	B	C	D	E	F	G	M	N	H	J	K	Holes	kg
TCTR-405015-18	500													165
		400	150	320	200	55	50	M16	M16	400	18	100	4	210
TCTR-406515-18	650													280
		500	200	400	250	75	50	M16	M16	500	18	100	6	325
TCTR-507520-18	750													430
		630	250	500	315	100	50	M16	M16	630	18	125	6	500
TCTR-637025-18	700													660
		800	300	640	400	135	50	M16	M16	800	18	150	6	785
TCTR-638525-18	850													1158
		1000	350	800	500	165	55	M20	M16	1000	18	150	6	1375

## DOUBLE SIDED TOOLING COLUMN

TABR Blank, Aluminum

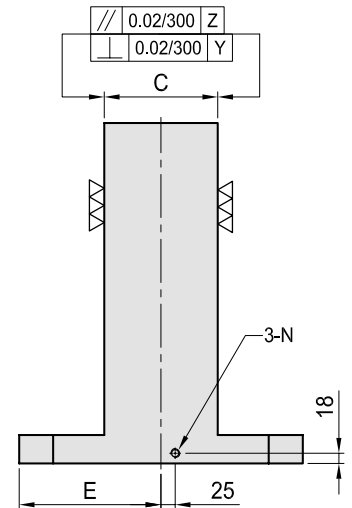
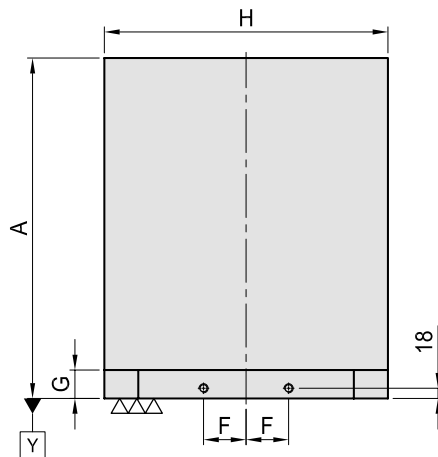
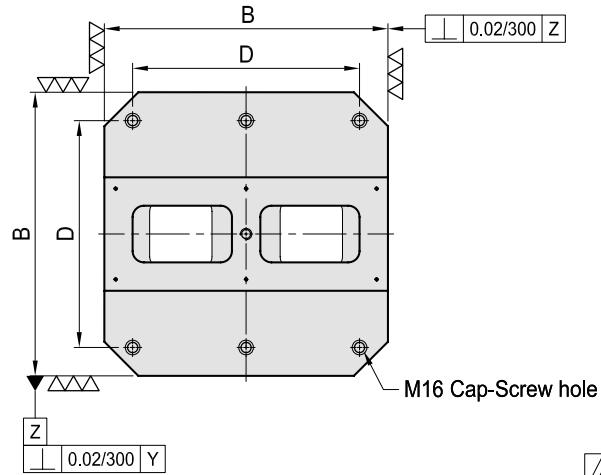

**Material:**

Material: High Strength Aluminum Casting

**Application:**

Horizontal Machining Center

**Features:**

Ready to accept a hole pattern for your special jig.

Eye bolt & top cover included

MODEL NO.	A	B	C	D	E	F	G	H	Holes	kg
TABR-405015	500	400	150	320	200	55	40	400	4	62
TABR-406515	650									86
TABR-506020	600	500	200	400	250	75	40	500	6	96
TABR-507520	750									135
TABR-637025	700	630	250	500	315	100	50	630	6	176
TABR-638525	850									202
TABR-808030	800	800	300	640	400	135	50	800	6	217
TABR-8010030	1000									318

## DUBLE SIDED TOOLING COLUMN

TAGR Grid, Aluminum

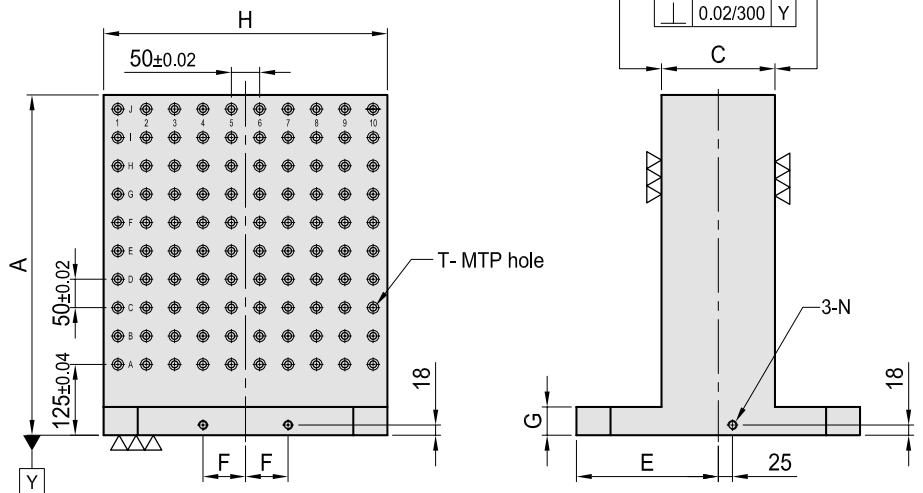
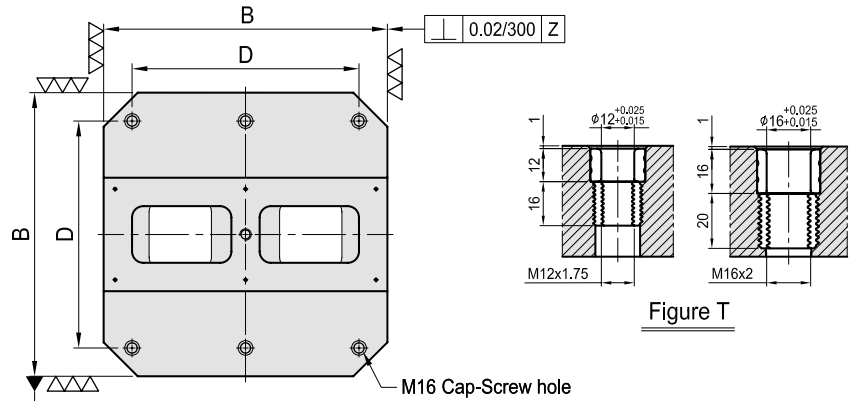

**Material:**

Material: High Strength Aluminum Casting

**Alignment Busing:**

SUJ2(JIS) / 100Cr6 (DIN), heat treated  
 Threaded Insert:  
 S45C(JIS) / CK45 (DIN), heat treated  
 Grid hole spacing:  $50 \pm 0.02$

**Application:**

Horizontal Machining Center

**Features:**

Alignment bushing & thread insert at every hole location, easily adapts to standardized jig components.

Eye bolt & top cover included

MODEL NO.	A	B	C	D	E	F	G	H	T	pcs	Holes	kg	
TAGR-405015-12	500	400	150	320	200	55	40	400	Ø12	M12	128	4	56
TAGR-406515-12	650										176		
TAGR-506020-12	600	500	200	400	250	75	40	500	Ø12	M12	200	6	91
TAGR-507520-12	750										260		
TAGR-637025-12	700	630	250	500	315	100	50	630	Ø12	M12	288	6	154
TAGR-638525-12	850										360		
TAGR-808030-12	800	800	300	640	400	135	50	800	Ø12	M12	420	6	214
TAGR-8010030-12	1000										540		

MODEL NO.	A	B	C	D	E	F	G	H	T	pcs	Holes	kg	
TAGR-405015-16	500	400	150	320	200	55	40	400	Ø16	M16	128	4	60
TAGR-406515-16	650										176		
TAGR-506020-16	600	500	200	400	250	75	40	500	Ø16	M16	200	6	103
TAGR-637025-16	700										288		
TAGR-638525-16	850	630	250	500	315	100	50	630	Ø16	M16	360	6	202
TAGR-808030-16	800										420		
TAGR-8010030-16	1000	800	300	640	400	135	50	800	Ø16	M16	540	6	318

## DOUBLE SIDED TOOLING COLUMN

TATR T-Slot, Aluminum

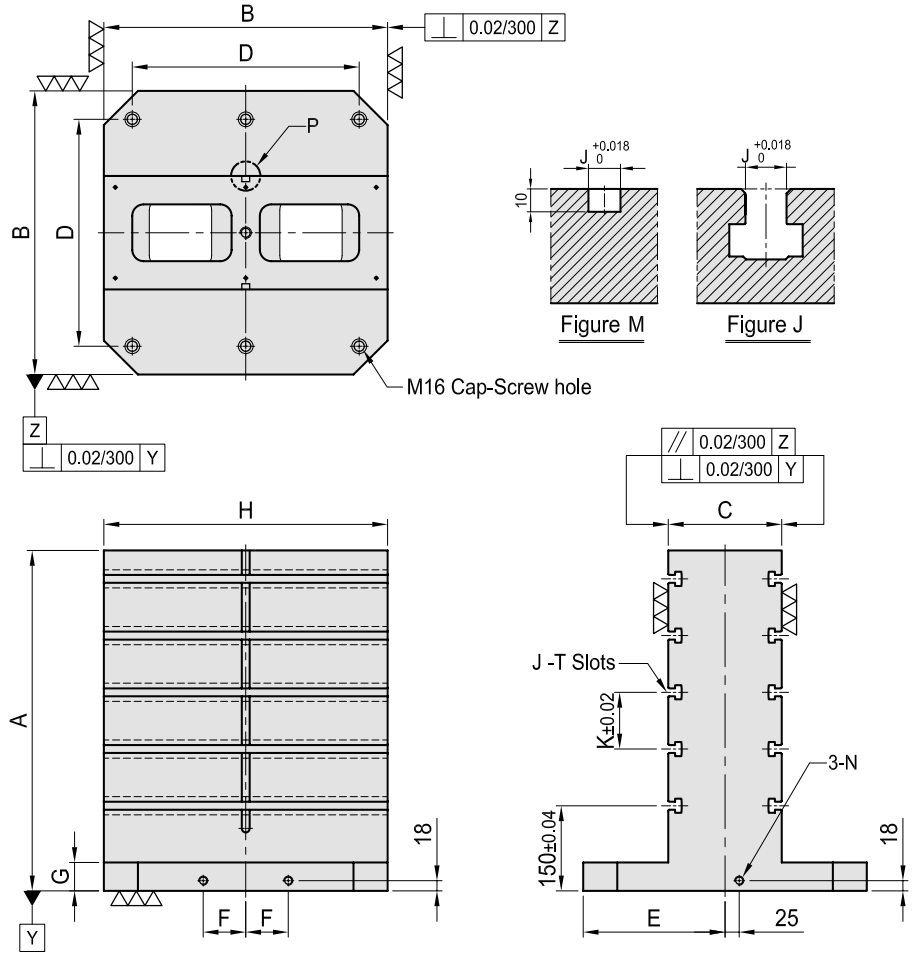

**Material:**

Material: High Strength Aluminium Casting

**Application:**

Horizontal Machining Center

**Features:**

T-Slots running horizontally, key-way running vertically, easily adapts to standardized jig components.

Eye bolt & top cover included

MODEL NO.	A	B	C	D	E	F	G	H	J	K	Holes	kg
TATR-405015-14	500	400	150	320	200	55	40	400	14	100	4	60
TATR-506020-14	600	500	200	400	250	75	40	500	14	100	6	87
TATR-507520-14	750											142
TATR-637025-14	700	630	250	500	315	100	50	630	14	125	6	165
TATR-638525-14	850											212
TATR-808030-14	800	800	300	640	400	135	50	800	14	150	6	243
TATR-8010030-14	1000											325

MODEL NO.	A	B	C	D	E	F	G	H	J	K	Holes	kg
TATR-405015-18	500	400	150	320	200	55	40	400	18	100	4	60
TATR-506015-18	600	500	200	400	250	75	40	500	18	100	6	86
TATR-507520-18	750											142
TATR-637025-18	700	630	250	500	315	100	50	630	18	125	6	163
TATR-638525-18	850											212
TATR-808030-18	800	800	300	640	400	135	50	800	18	150	6	240
TATR-8010030-18	1000											325

# CROSS TOOLING COLUMN

TCBC Blank, Cast Iron

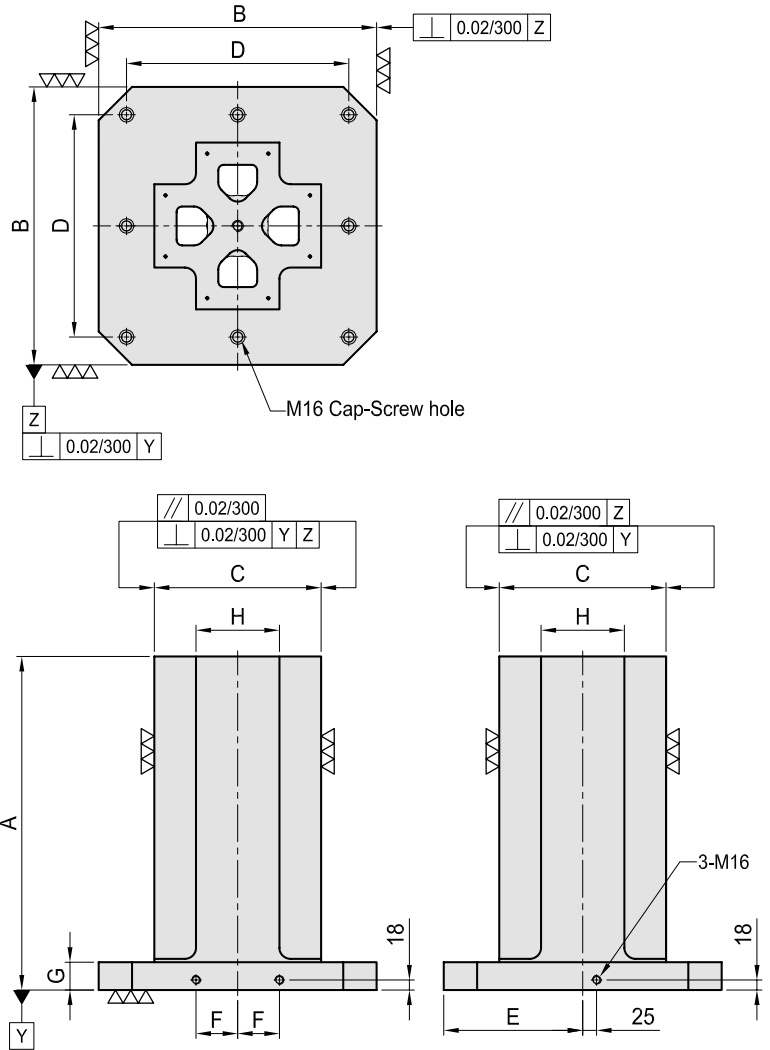
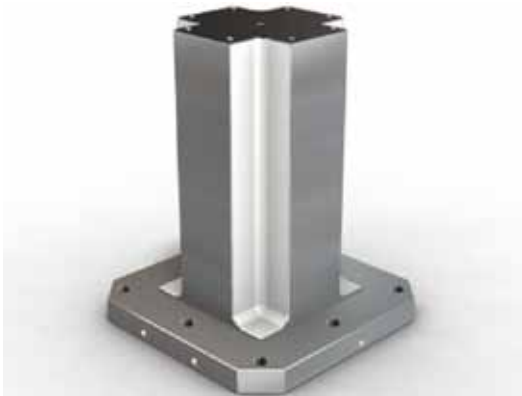

**Material / Finish:**

Material: Cast Iron FC300(JIS) / GG30 (DIN)  
Heat treated (Normalized)

**Application:**

Horizontal Machining Center

**Features:**

Ready to accept a hole pattern for your special jig.

Eye bolt & top cover included

MODEL NO.	A	B	C	D	E	F	G	H	Holes	kg
TCBC-405025	500	400	250	320	200	55	50	125	4	154
TCBC-406525	650									188
TCBC-506030	600	500	300	400	250	75	50	150	8	244
TCBC-507530	750									287
TCBC-637035	700	630	350	500	315	100	50	200	8	373
TCBC-638535	850									424
TCBC-808050	800	800	500	640	400	135	50	300	8	648
TCBC-8010050	1000									753

# CROSS TOOLING COLUMN

TCGC Grid, Cast Iron

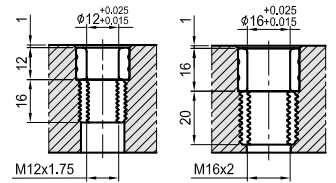
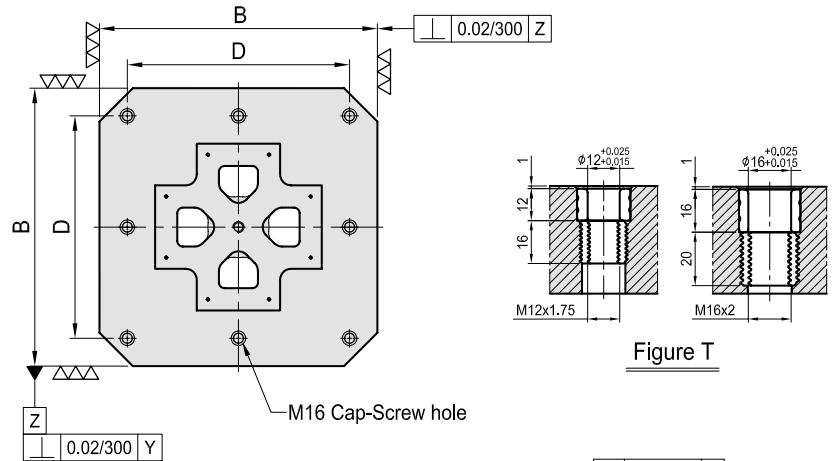
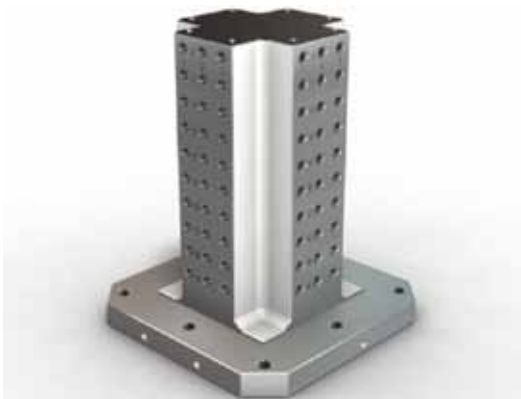
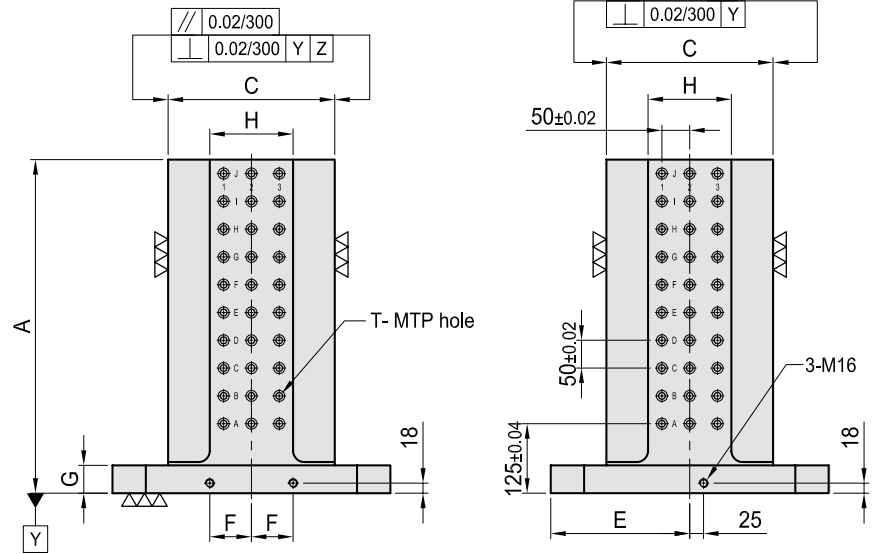

Figure T



**Material / Finish:**

Material: Cast Iron FC300(JIS) / GG30 (DIN)  
Heat treated (Normalized)

**Alignment Busing:**

SUJ2(JIS) / 100Cr6 (DIN), heat treated  
Threaded Insert:  
S45C(JIS) / CK45 (DIN), heat treated  
Grid hole spacing:  $50 \pm 0.02$

**Application:**

Horizontal Machining Center

**Features:**

Alignment bushing & thread insert at every hole location, easily adapts to standardized jig components.

Eye bolt & top cover included

MODEL NO.	A	B	C	D	E	F	G	H	T	pcs	Holes	kg
TCGC-405025-12	500									64		152
		400	250	320	200	55	50	125	Ø12	M12	4	186
TCGC-406525-12	650									88		186
		400	250	320	200	55	50	125	Ø12	M12	4	186
TCGC-506030-12	600									120		250
		500	300	400	250	75	50	150	Ø12	M12	8	250
TCGC-507530-12	750									156		293
		500	300	400	250	75	50	150	Ø12	M12	8	293
TCGC-637035-12	700									192		368
		630	350	500	315	100	50	200	Ø12	M12	8	368
TCGC-638535-12	850									240		418
		630	350	500	315	100	50	200	Ø12	M12	8	418
TCGC-808050-12	800									336		640
		800	500	640	400	135	50	300	Ø12	M12	8	640
TCGC-8010050-12	1000									432		740
		800	500	640	400	135	50	300	Ø12	M12	8	740

MODEL NO.	A	B	C	D	E	F	G	H	T	pcs	Holes	kg
TCGC-405025-16	500									64		151
		400	250	320	200	55	50	125	Ø16	M16	4	184
TCGC-406525-16	650									88		184
		400	250	320	200	55	50	125	Ø16	M16	4	184
TCGC-506030-16	600									120		247
		500	300	400	250	75	50	150	Ø16	M16	8	247
TCGC-507530-16	750									156		290
		500	300	400	250	75	50	150	Ø16	M16	8	290
TCGC-637035-16	700									192		364
		630	350	500	315	100	50	200	Ø16	M16	8	364
TCGC-638535-16	850									240		413
		630	350	500	315	100	50	200	Ø16	M16	8	413
TCGC-808050-16	800									336		633
		800	500	640	400	135	50	300	Ø16	M16	8	633
TCGC-8010050-16	1000									432		733
		800	500	640	400	135	50	300	Ø16	M16	8	733



## HEXAGONAL CUBE

TCBH Blank, Cast Iron

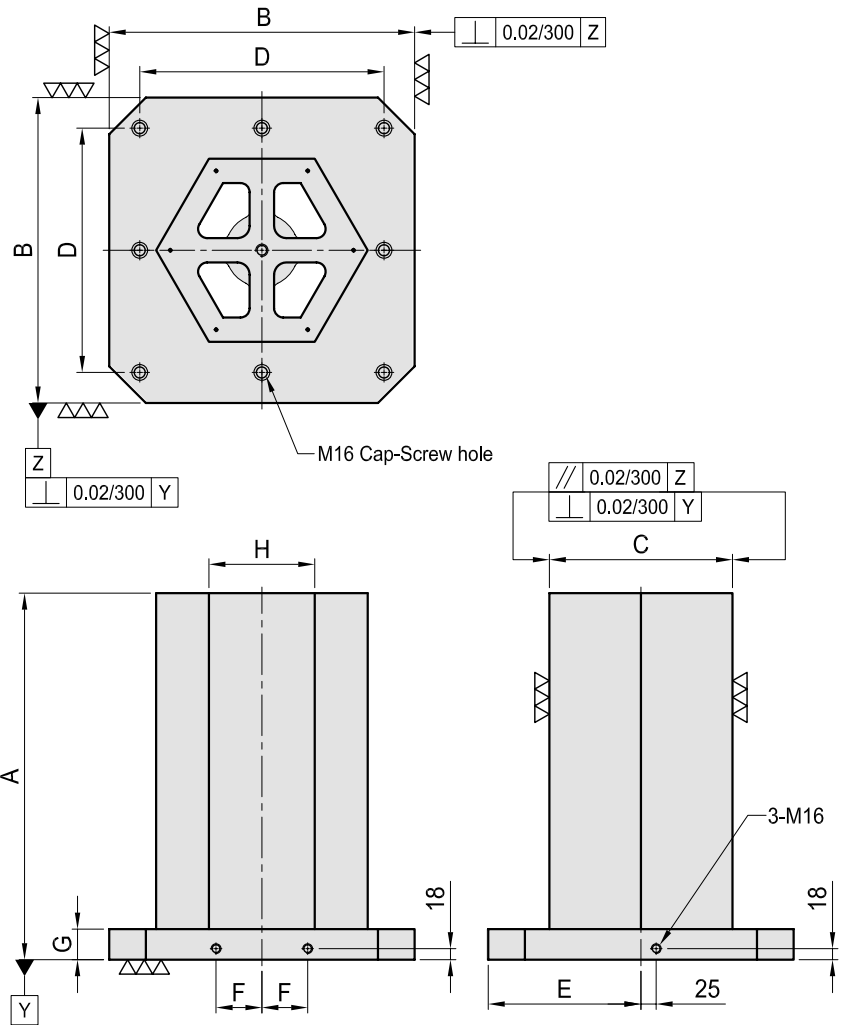

**Material / Finish:**

Material: Cast Iron FC300(JIS) / GG30 (DIN)  
Heat treated (Normalized)

**Application:**

Horizontal Machining Center

**Features:**

Ready to accept a hole pattern for your special jig.

Eye bolt & top cover included

MODEL NO.	A	B	C	D	E	F	G	H	Holes	kg
TCBH-405025	500	400	250	320	200	55	50	144	4	151
TCBH-406525	650									183
TCBH-506030	600	500	300	400	250	75	50	173	8	233
TCBH-507530	750									272
TCBH-637035	700	630	350	500	315	100	50	202	8	361
TCBH-638535	850									408
TCBH-808050	800	800	500	640	400	135	50	289	8	619
TCBH-8010050	1000									713

# HEXAGONAL CUBE

TCGH Grid, Cast Iron

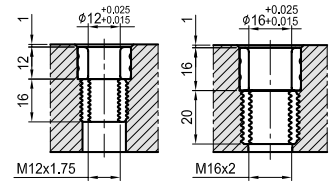
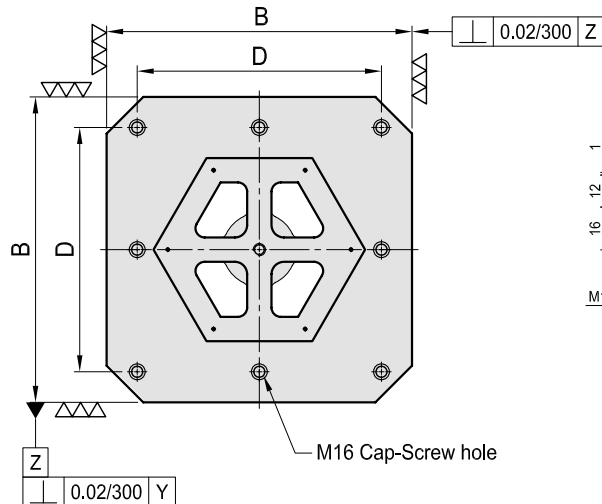

Figure T

**Material / Finish:**

Material: Cast Iron FC300(JIS) / GG30 (DIN)  
Heat treated (Normalized)

**Alignment Busing:**

SUJ2(JIS) / 100Cr6 (DIN), heat treated  
Threaded Insert:  
S45C(JIS) / CK45 (DIN), heat treated  
Grid hole spacing:  $50 \pm 0.02$

**Application:**

Horizontal Machining Center

**Features:**

Alignment bushing & thread insert at every hole location, easily adapts to standardized jig components.

Eye bolt & top cover included

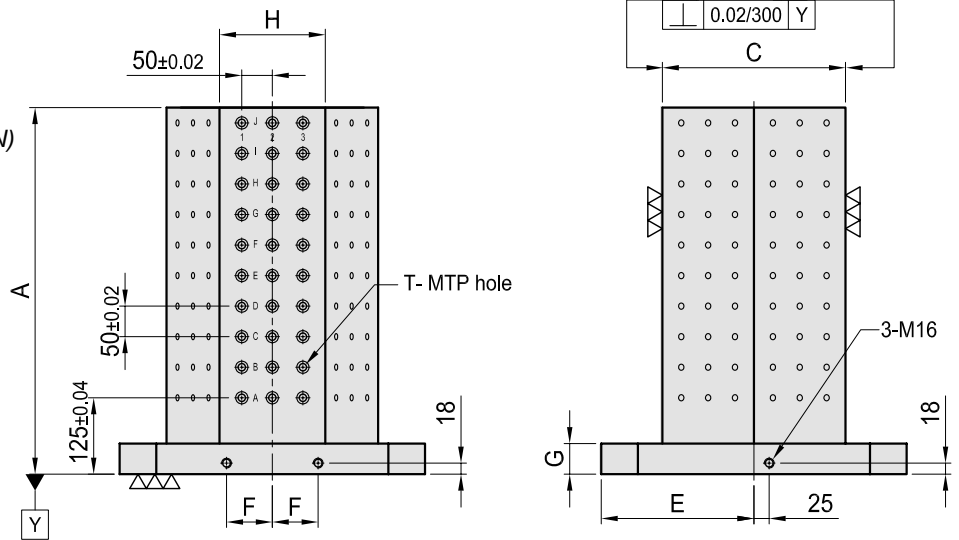

MODEL NO.	A	B	C	D	E	F	G	H	T	pcs	Holes	kg
TCGH-405025-12	500									96		149
		400	250	320	200	55	50	144	Ø12	M12	4	180
TCGH-406525-12	650									132		177
		500	300	400	250	75	50	173	Ø12	M12	8	224
TCGH-506030-12	600									180		228
		500	300	400	250	75	50	173	Ø12	M12	8	267
TCGH-507530-12	750									234		267
		630	350	500	315	100	50	202	Ø12	M12	8	356
TCGH-637035-12	700									216		356
		630	350	500	315	100	50	202	Ø16	M16	8	407
TCGH-638535-12	850									270		407
		800	500	640	400	135	50	289	Ø12	M12	8	609
TCGH-808050-12	800									420		609
		800	500	640	400	135	50	289	Ø16	M16	8	700
TCGH-8010050-12	1000									540		700

MODEL NO.	A	B	C	D	E	F	G	H	T	pcs	Holes	kg
TCGH-405025-16	500									69		147
		400	250	320	200	55	50	144	Ø16	M16	4	177
TCGH-406525-16	650									132		177
		500	300	400	250	75	50	173	Ø16	M16	8	224
TCGH-506030-16	600									180		224
		500	300	400	250	75	50	173	Ø16	M16	8	262
TCGH-507530-16	750									234		262
		630	350	500	315	100	50	202	Ø16	M16	8	351
TCGH-637035-16	700									216		351
		630	350	500	315	100	50	202	Ø16	M16	8	396
TCGH-638535-16	850									270		396
		800	500	640	400	135	50	289	Ø16	M16	8	600
TCGH-808050-16	800									420		600
		800	500	640	400	135	50	289	Ø16	M16	8	688
TCGH-8010050-16	1000									540		688

## OCTAGONAL CUBE

TCBE Blank, Cast Iron

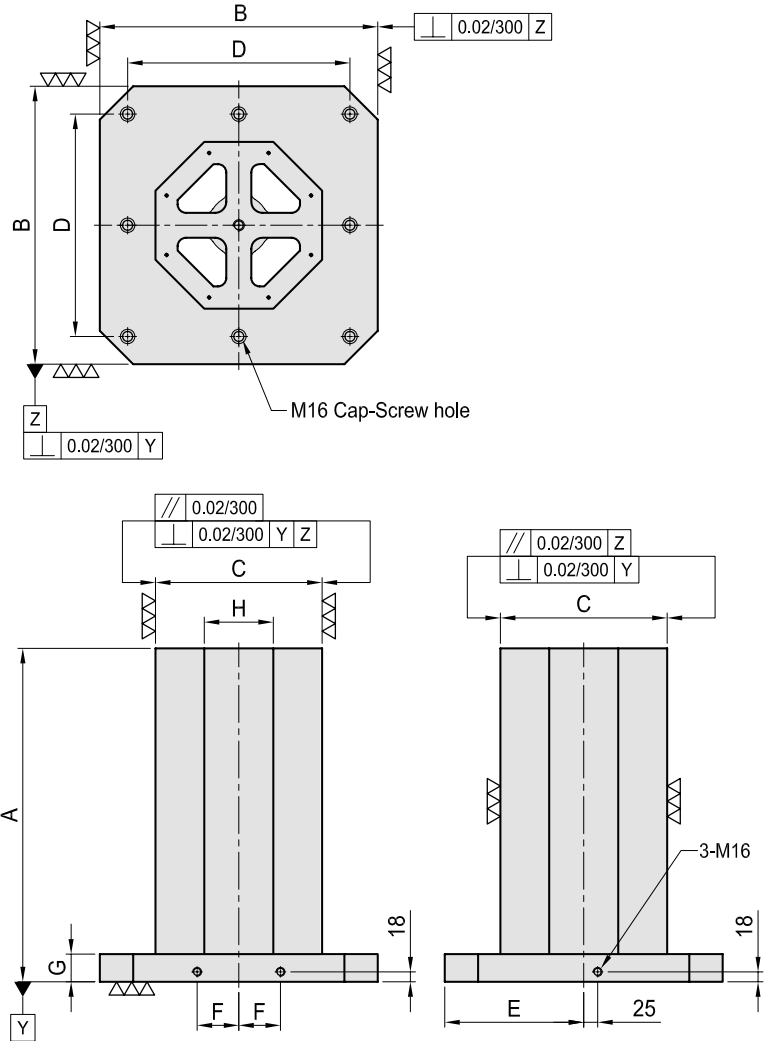

**Material / Finish:**

Material: Cast Iron FC300(JIS) / GG30 (DIN)  
Heat treated (Normalized)

**Application:**

Horizontal Machining Center

**Features:**

Ready to accept a hole pattern for your special jig.

Eye bolt & top cover included

MODEL NO.	A	B	C	D	E	F	G	H	Ho-les	kg
TCBE-405025	500	400	250	320	200	55	50	103	4	148
TCBE-406525	650									179
TCBE-506030	600	500	300	400	250	75	50	124	8	227
TCBE-507530	750									264
TCBE-637035	700	630	350	500	315	100	50	145	8	350
TCBE-638535	850									395
TCBE-808050	800	800	500	640	400	135	50	207	8	622
TCBE-8010050	1000									711

# OCTAGONAL CUBE

TCGE Grid, Cast Iron

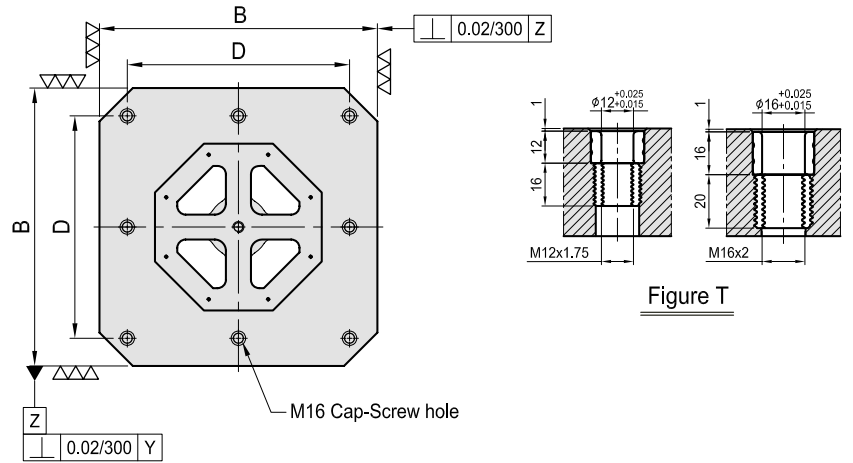

Figure T

**Material / Finish:**

Material: Cast Iron FC300(JIS) / GG30 (DIN)  
Heat treated (Normalized)

**Alignment Busing:**

SUJ2(JIS) / 100Cr6 (DIN), heat treated  
Threaded Insert:  
S45C(JIS) / CK45 (DIN), heat treated  
Grid hole spacing:  $50 \pm 0.02$

**Application:**

Horizontal Machining Center

**Features:**

Alignment bushing & thread insert at every hole location, easily adapts to standardized jig components.

Eye bolt & top cover included

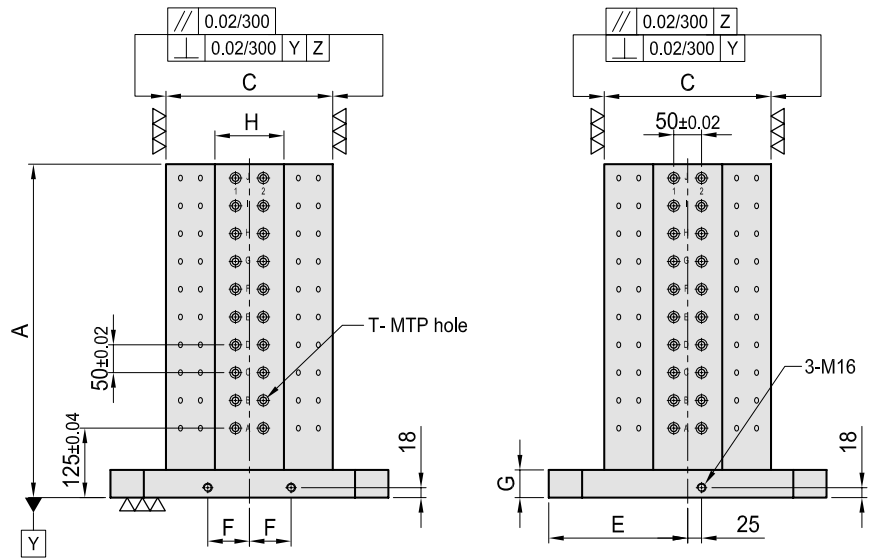

MODEL NO.	A	B	C	D	E	F	G	H	T	pcs	Holes	kg	
TCGE-405025-12	500	400	250	320	200	55	50	103	Ø12	M12	128	4	145
TCGE-406525-12	650										176		175
TCGE-506030-12	600	500	300	400	250	75	50	124	Ø12	M12	160	8	223
TCGE-507530-12	750										208		259
TCGE-637035-12	700	630	350	500	315	100	50	145	Ø12	M12	192	8	345
TCGE-638535-12	850										240		389
TCGE-808050-12	800	800	500	640	400	135	50	207	Ø12	M12	448	8	611
TCGE-8010050-12	1000										576		697

MODEL NO.	A	B	C	D	E	F	G	H	T	N	pcs	Holes	kg
TCGE-405025-16	500	400	250	320	200	55	50	103	Ø16	M16	128	4	142
TCGE-406525-16	650										176		171
TCGE-506030-16	600	500	300	400	250	75	50	124	Ø16	M16	160	8	219
TCGE-507530-16	750										208		255
TCGE-637035-16	700	630	350	500	315	100	50	145	Ø16	M16	192	8	341
TCGE-638535-16	850										240		384
TCGE-808050-16	800	800	500	640	400	135	50	207	Ø16	M16	448	8	601
TCGE-8010050-16	1000										576		685

## M / C ANGLE PLATE

TCBA Blank, Cast Iron

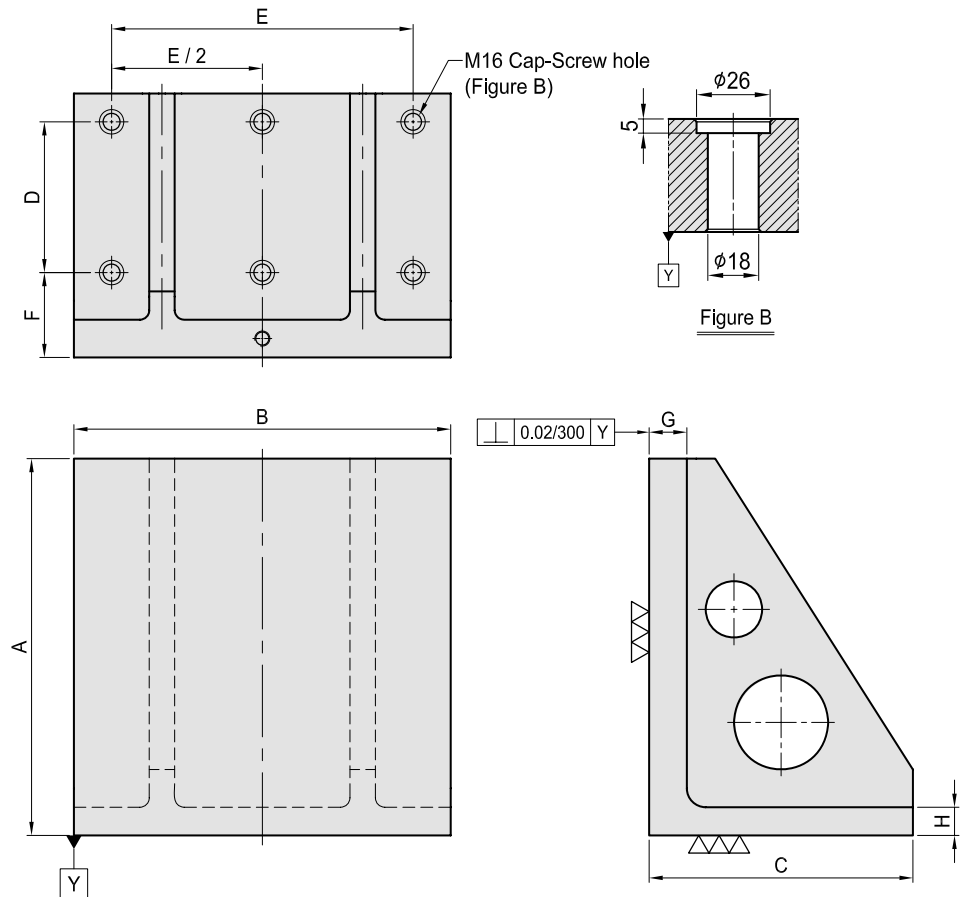

**Material / Finish:**

Material:  
Cast Iron FC300(JIS) / GG30 (DIN)  
Heat treated (Normalized)

**Application:**

HMC / VMC

**Features:**

Ready to accept a hole pattern for your special jig.

MODEL NO.	A	B	C	D	E	F	G	H	Holes	kg
TCBA-303022	300	300	220	100	250	90	40	30	6	50
TCBA-404028	400	400	280	160	320					90
TCBA-505034	500	500	340	200	400	100	50	35	6	165
TCBA-636344	630	630	435	250	500					100
TCBS-808053	800	800	525	320	640	115	50	45	6	475

# M / C ANGLE PLATE

TCGA Grid, Cast Iron

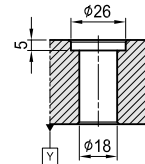
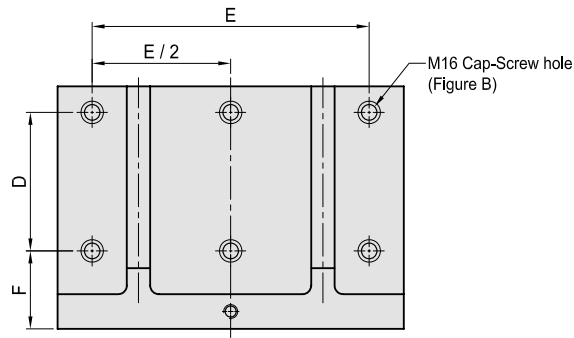

Figure B

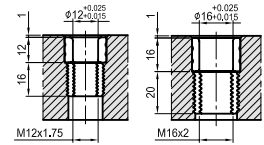
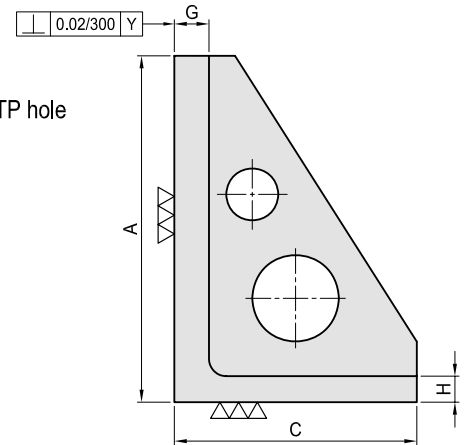
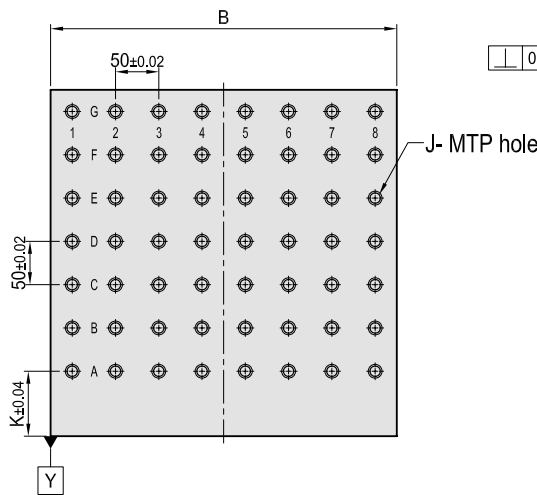

Figure J



**Material / Finish:**

Material:  
Cast Iron FC300(JIS) / GG30 (DIN)  
Heat treated (Normalized)

**Alignment Busing:**

SUJ2(JIS) / 100Cr6 (DIN), heat treated  
Threaded Insert:  
S45C(JIS) / CK45 (DIN), heat treated  
Grid hole spacing: 50 ± 0.02

**Application:**

HMC / VMC

**Features:**

Alignment bushing & thread insert at every hole location, easily adapts to standardized jig components.

MODEL NO.	A	B	C	D	E	F	G	H	J	K	pcs	Holes	kg	
TCGA-303022-12	300	300	220	100	250	90	40	30	Ø12	M12	75	30	6	50
TCGA-404028-12	400	400	280	160	320						75	56		87
TCGA-505034-12	500	500	340	200	400	90	50	35	Ø12	M12	75	90	6	173
TCGA-636344-12	630	630	435	250	500						100	40		40
TCGA-808054-12	800	800	525	320	640	115	50	45	Ø12	M12	75	240	6	477
TCGA-303022-16	300	300	220	100	250	90	40	30	Ø16	M16	75	30	6	46
TCGA-404028-16	400	400	280	160	320						75	56		85
TCGA-505034-16	500	500	340	200	400	90	50	35	Ø16	M16	75	90	6	170
TCGA-636344-16	630	630	435	250	500						100	40		40
TCGA-808054-16	800	800	525	320	640	115	50	45	Ø16	M16	75	240	6	470

# M / C ANGLE PLATE

TCTA T-Slot, Cast Iron

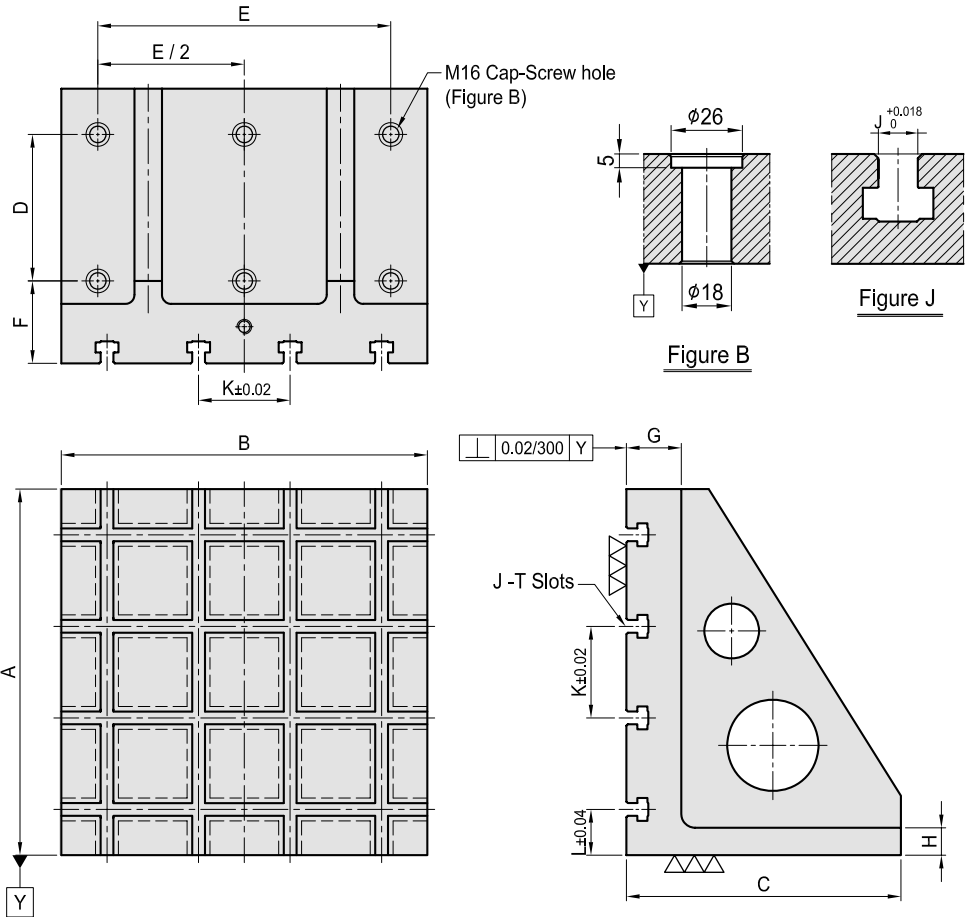

**Material / Finish:**

Material:  
Cast Iron FC300(JIS) / GG30 (DIN)  
Heat treated (Normalized)

**Application:**

HMC / VMC

**Features:**

T-Slots running in 2 directions, easily adapts to standardized jig components.

MODEL NO.	A	B	C	D	E	F	G	H	J	K	L	Ho-les	kg
TCTA-303022-14	300	300	220	100	250	90	60	30	14	100	50	6	53
TCTA-404028-12	400	400	300	160	320								101
TCTA-505034-12	500	500	350	200	400	90	60	35	14	100	50	6	170
TCTA-636344-12	630	630	450	250	500	100	65	40					125
TCTA-808054-12	800	800	550	320	640	115	75	45	14	150	100	6	566
TCTA-303022-18	300	300	220	100	250	90	60	30	18	100	50	6	51
TCTA-404028-18	400	400	300	160	320								96
TCTA-505034-18	500	500	350	200	400	90	60	35	18	100	50	6	162
TCTA-636344-18	630	630	450	250	500	100	65	40					125
TCTA-808054-18	800	800	550	320	640	115	75	45	18	150	100	6	555

## OK-VISE PLATFORMS

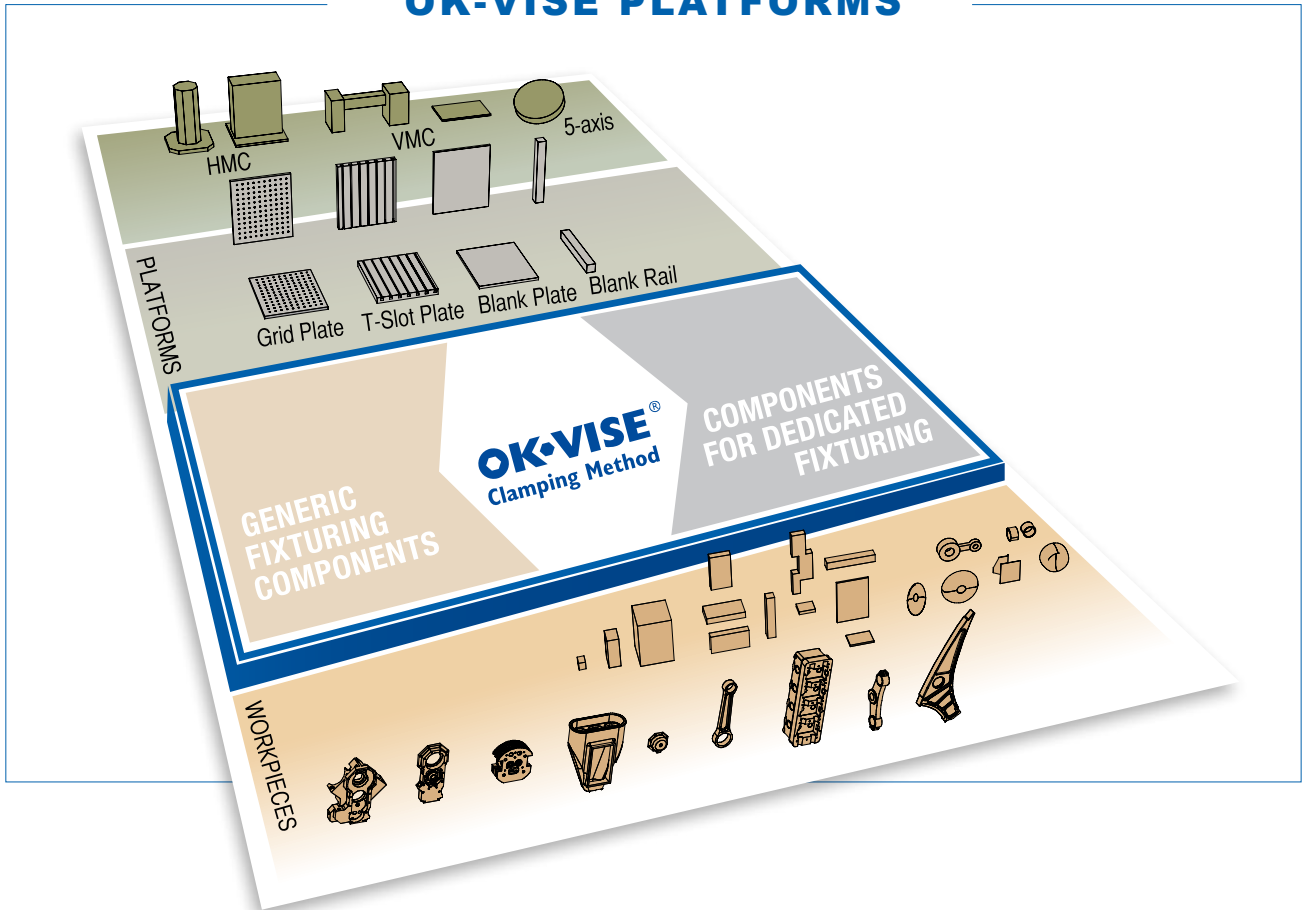

The original OK-VISE low-profile clamps are known worldwide as a core component of any modern workholding system. In the machining industry, OK-VISE name means quality.

The mother company of OK-VISE OY is Kytola Instruments. The company is known for manufacturing precision instruments.

[www.kytola.com](http://www.kytola.com)



MANUFACTURER

DISTRIBUTOR

# OK-VISE®

OK-Vise Oy, P.O.Box 5  
 40951 Murame, Finland  
 Tel. +358 20 7790 699, Fax +358 14 631 419  
 Technical questions: [support@ok-vise.com](mailto:support@ok-vise.com)  
[www.ok-vise.com](http://www.ok-vise.com)